

无火焰泄爆装置选型参数

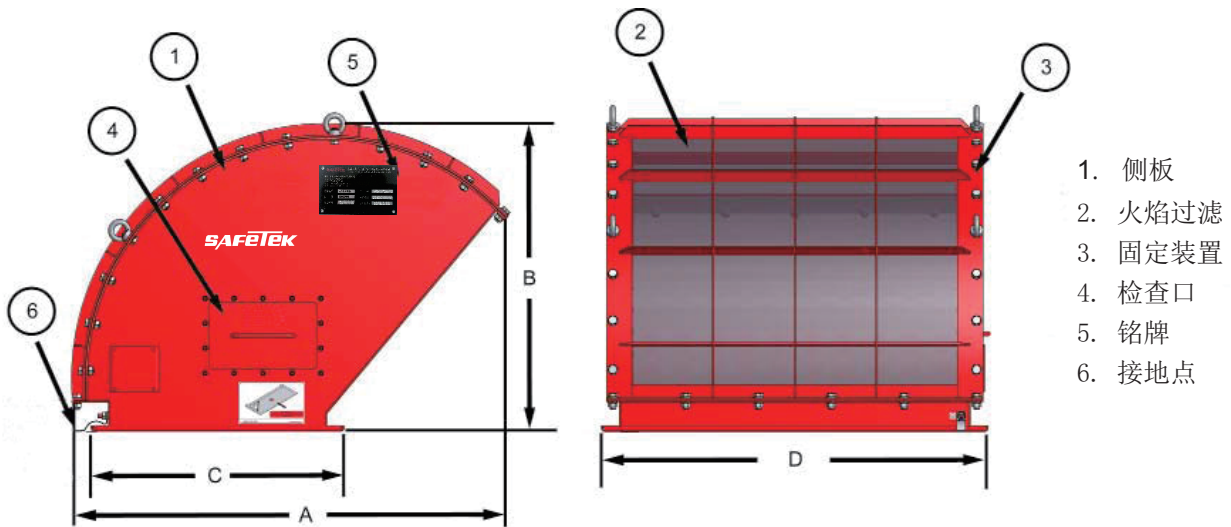

无火焰泄爆装置		外形尺寸				设备重量	螺栓规格	
型号	编号	A	B	C	D	KG	数量	规格
200X500	SFK-W-F-1	594.5	472.9	290	580	40	22	M10X30
300X500	SFK-W-F-2	761.7	572.9	390	580	50	22	M10X30
410X580	SFK-W-F-3	950.2	683	500	670	75	28	M12X30
410X910	SFK-W-F-4	950.2	683	500	1000	120	36	M12X30
690X690	SFK-W-F-5	1426.1	962	800	800	200	40	M12X30
910X910	SFK-W-F-6	1801.1	1182	1000	1000	280	48	M12X30
910X1245	SFK-W-F-7	1801.1	1182	1000	1335	300	56	M12X30

注：参数以实物为准。